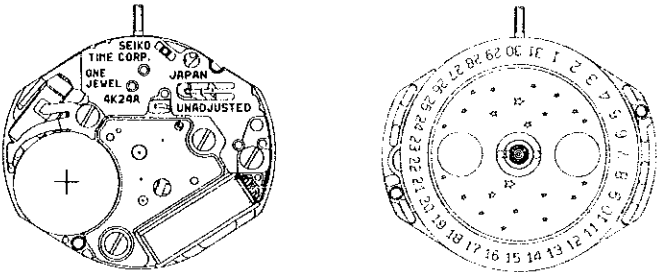

# PARTS CATALOGUE/TECHNICAL GUIDE

## Cal. 4K24A

### [SPECIFICATIONS]

Cal. No.		4K24A
Item		
Movement		 <p style="text-align: right;">(x 2.0)</p>
Movement size	Outside diameter	17.6mm between 6 o'clock and 12 o'clock sides 15.3mm between 3 o'clock and 9 o'clock sides
	Casing diameter	φ17.1mm
	Height	3.4mm
Time indication		3 hands
Driving system		Step motor (Load compensated driving pulse type)
Additional mechanism		<ul style="list-style-type: none"> <li>• Numerical date calendar</li> <li>• Moon phase display</li> <li>• Instant calendar (date) setting device</li> <li>• Instant moon phase setting device</li> <li>• Train wheel setting device</li> <li>• Electronic circuit reset switch</li> </ul>
Loss/gain		Monthly rate at normal temperature range: less than 15 seconds
Regulation system		Nil
Measuring gate by quartz tester		Use 10-second gate.
Battery		SEIKO SR621SW, Maxell SR621SW, SONY SR621SW, EVEREADY 364 Battery life is approximately 2 years. Voltage: 1.55V
Jewels		1 jewel

# PARTS CATALOGUE

Cal. 4K24A

Disassembling procedures Figs.: ① → ④⑩

Reassembling procedures Figs.: ④⑩ → ①

Lubricating: Types of oil		Oil quantity
●	Moebius A	∞ Normal quantity
∞	SEIKO Watch Oil S-6	▷ Extremely small

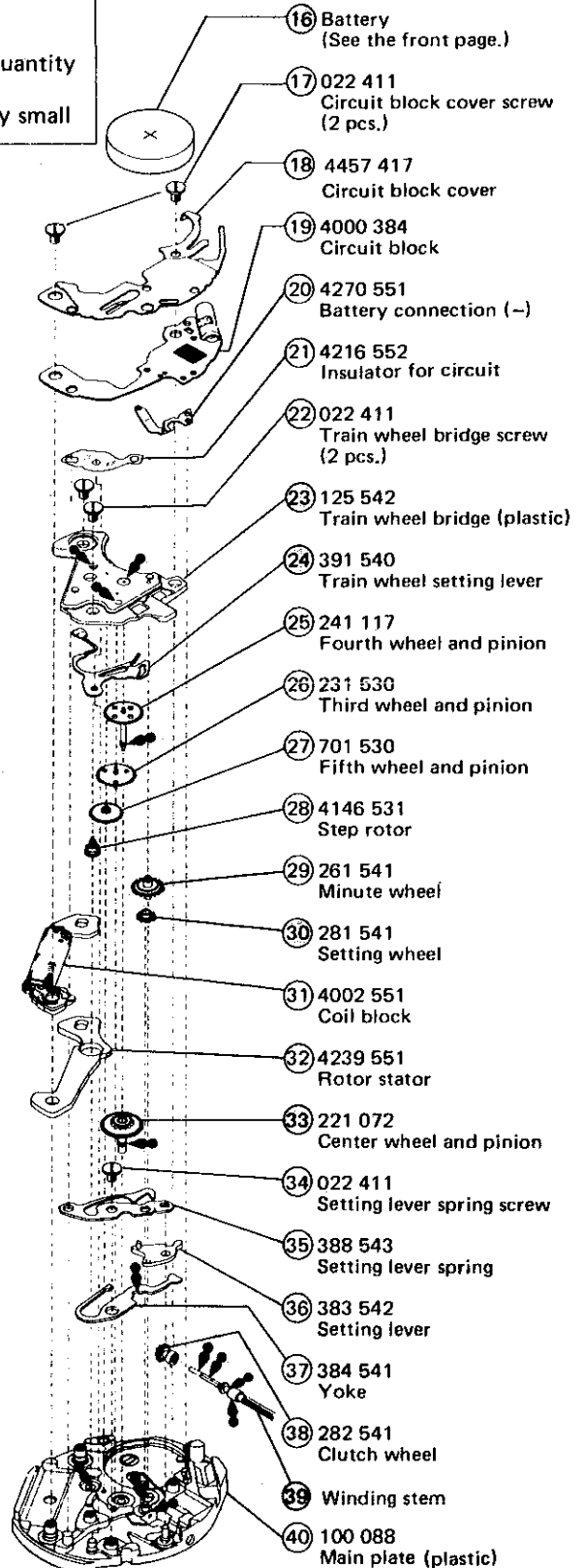
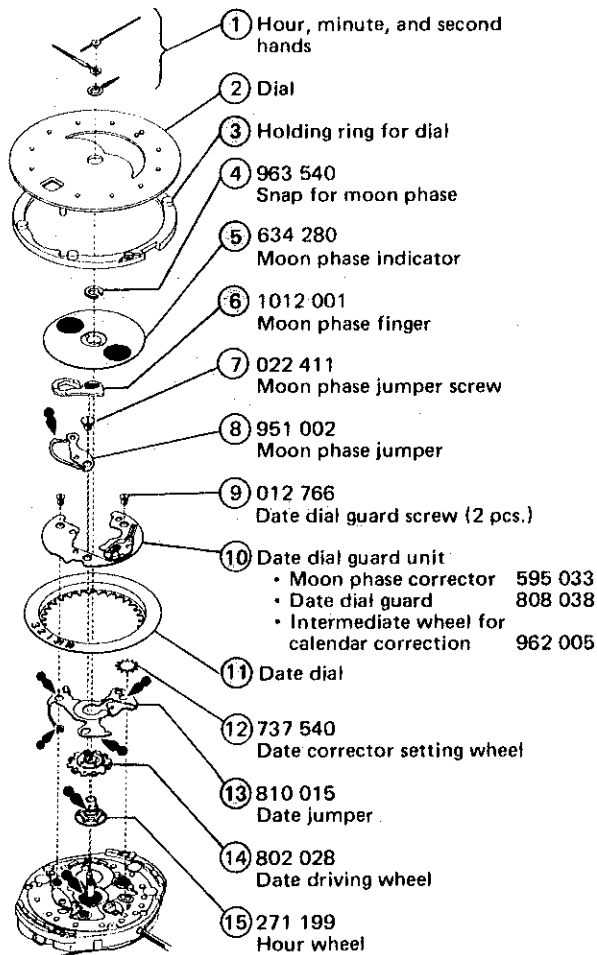

	022 411 ● Circuit block cover screw (2 pcs.) ● Train wheel bridge screw (2 pcs.) ● Setting lever spring screw (1 pc.) ● Moon phase jumper screw (1 pc.)
	012 766 ● Date dial guard screw (2 pcs.) (Both Phillips head and slotted head screws can be used.)

⊙ ⇨ Please see the remarks on the following pages.

**Remarks:**

- ③ Holding ring for dial 884 161
- ⑪ Date dial

Part code	Position of crown & calendar	Color of figure	Color of background
801 411	Crown : 3 o'clock Calendar: 6 o'clock	Black	White
801 413		Black	Gold
801 414		Gold	Black

- ③⑨ Winding stem 351 546

The types of holding ring for dial, date dial and winding stem are determined based on the design of cases. Check the case number and refer to the "SEIKO Casing Parts Catalogue" to choose a corresponding holding ring for dial, date dial and winding stem. For details of date dial, please refer to the "List of date dial".

## TECHNICAL GUIDE

- The explanation here is only for the particular points of Cal. 4K24A.
- For repairing, checking and measuring procedures, refer to the "TECHNICAL GUIDE, GENERAL INSTRUCTIONS".

### I. STRUCTURE OF THE CIRCUIT BLOCK

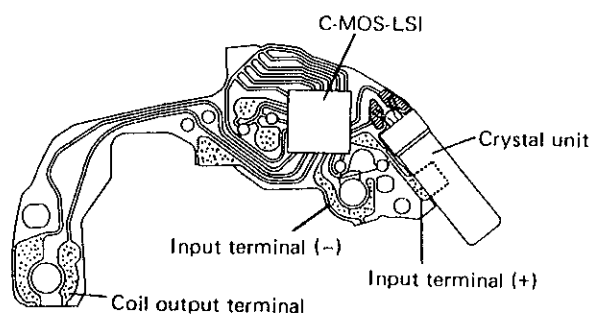

### II. REMARKS ON DISASSEMBLING AND REASSEMBLING

Use the universal movement holder for disassembling and reassembling.

- ① Hour, minute, and second hands

- **How to install**

Place the movement directly on a flat metal plate or the like and install the hands, since the main plate and train wheel bridge are made of plastics.

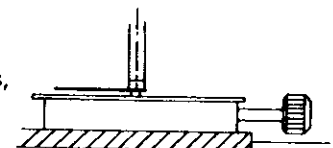

## ⑤ Moon phase indicator

### • How to remove

To remove the moon phase indicator, catch the two indented portions at its center with tweezers to lift it up.

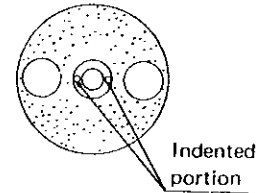

### • How to install

Before installing the moon phase indicator, set the moon phase corrector and moon phase finger as indicated in the illustration. If they are out of the specified position, the parts may be deformed.

To install the moon phase indicator, catch the indented portions with tweezers and turn it clockwise while lightly pressing it.

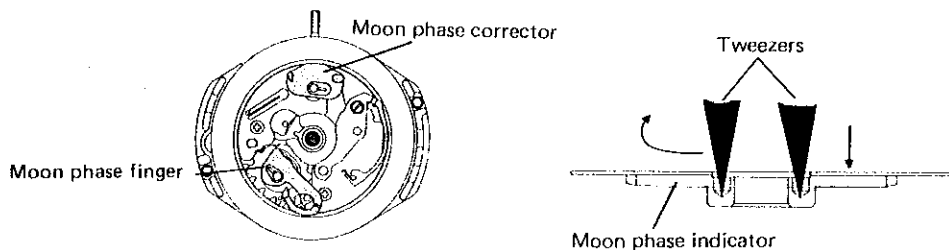

## ⑥ Moon phase finger

The moon phase finger is a plastic part with some elasticity in the contact with the date driving wheel axle. Therefore, good care should be taken not to deform the moon phase finger when installing or removing it.

### • How to remove

Insert a tip of tweezers, etc. into the part indicated by the arrow in the illustration, and pry up the moon phase finger.

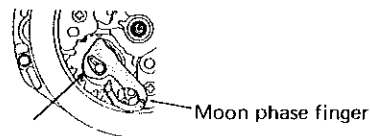

## ⑩ Date dial guard unit

Date dial guard unit consists of the moon phase corrector, date dial guard and intermediate wheel for calendar correction.

The moon phase corrector is a plastic part, and therefore, be sure to follow the procedure below when disassembling it. However, do not disassemble it unless necessary.

### • How to disassemble

- (1) Loosen the date dial guard screws (2 pcs.), and remove whole of the date dial guard unit.
- (2) Place the date dial guard unit on the two metal plates placed side by side so that the intermediate wheel for calendar correction lies between them.

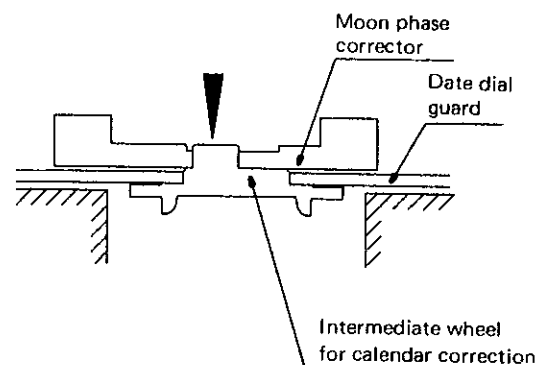

- (3) Lightly press the axle head of the intermediate wheel for calendar correction with a tip of tweezers.

Lubricating:  Moebius A

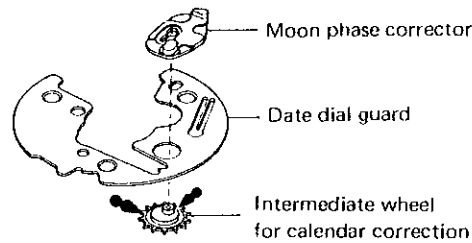

● **How to reassemble**

- (1) Install the intermediate wheel for calendar correction and date dial guard individually onto the movement.
- (2) Tighten the date dial guard screws first.
- (3) Set the moon phase corrector to the axle of the intermediate wheel for calendar correction. In doing so, lightly press the center part of the moon phase corrector.

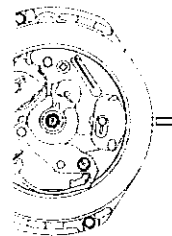

⑬ **Date jumper**

If the guide hole of the date jumper is too tight for the guide axle of the main plate when installing the date jumper, press "A" portion in the illustration with tweezers.

● **Lubricating**

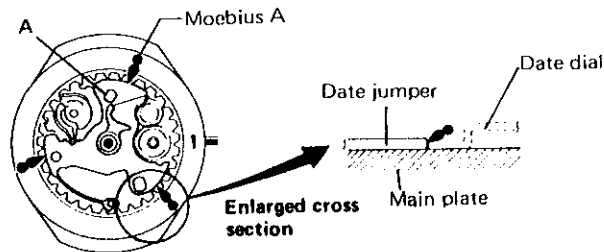

⑯ **Battery**

● **How to install**

When installing the battery, check that the plus lead terminal of the circuit block cover securely touches the side face of the battery.

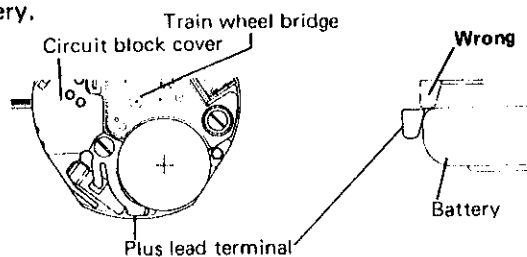

## 23 Train wheel bridge

- **Setting position**

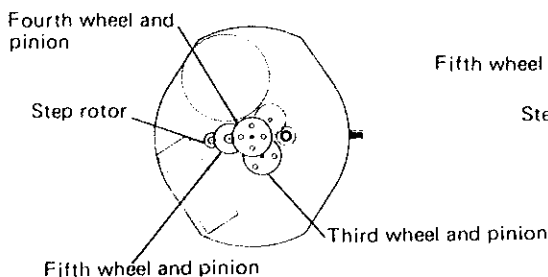

- **Cleaning**

Use Daiflon S-3 for cleaning.

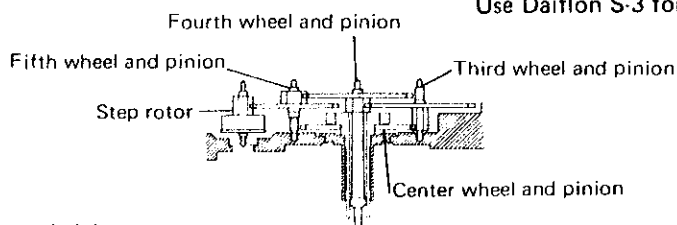

## 24 Train wheel setting lever

- **Setting position**

- **Lubricating**

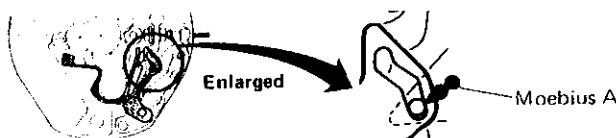

## 30 Setting wheel

- **How to install**

Take care not to install the setting wheel up side down.

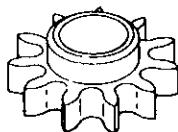

(Main plate side)

## 33 Center wheel and pinion

- **Lubricating**

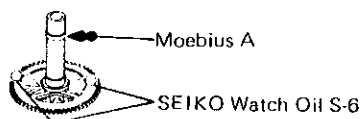

## III. VALUE CHECKING

- **Coil block resistance**

2.7K $\Omega$  ~ 4.1K $\Omega$

- **Current consumption**

For the whole of the movement : less than 1.4 $\mu$ A  
 For the circuit block alone : less than 0.4 $\mu$ A

### Remarks:

- When the current consumption exceeds the standard value for the whole of the movement but less than the standard value for the circuit block alone, overhaul and clean the movement parts and then measure current consumption for the whole of the movement again. The driving pulse generated to compensate a heavy load that may apply on the gear train, etc. is considered to cause excessive current consumption for the whole of the movement.