

SEIKO

QUARTZ

(Cal. 5C20A)
(Cal. 5C23A)

PARTS
CATALOGUE

Cal. 5C20A, 5C23A

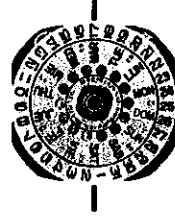
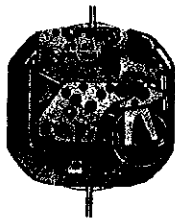

Cal. 5C23A



122 854



125 800



221 800



231 855



241 801



261 800



271 801



281 800



☆282 858



☆354 800



☆354 856



383 800



383 855



384 800



384 856



388 800



389 855



391 801



☆470 720



604 800



610 800



644 800



701 855



712 801



737 800



766 800



☆801 635



808 800



810 800



816 800



837 800

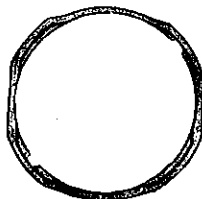

☆866 526



948 800



950 800



962 855



963 725



986 855



4001 525



4002 855



4146 855



4216 525



4225 525



4239 525



4246 525



4246 526

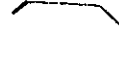

4259 855



4270 525



4281 525



4457 530



☆Maxell SR721W



022 427



022 436



022 780

2/1

Cal. 5C20A, 5C23A

Characteristics

	5C20A	5C23A
Casing diameter	24.0 × 21.0 × 22.0 mm	
Maximum height	2.9 mm	3.3 mm
Jewels	5 j	
Frequency of quartz crystal oscillator	32,768 Hz (Hz=Hertz Cycles per second)	
Driving system	Step motor (2 poles)	
Regulation system	Rotary step switch	
Train wheel setting		○
Instant setting device for day and date calendar	—	○

PART NO.	PART NAME	PART NO.	PART NAME
122 854	Center wheel bridge	4002 855	Coil block
125 800	Train wheel bridge	4146 855	Step rotor
221 800	Center wheel & pinion (Cal.5C23A)	4216 525	Insulator for alarm lead terminal
221 802	Center wheel & pinion (Cal.5C20A)	4225 525	Battery clamp
231 855	Third wheel & pinion	4239 525	Rotor stator
241 801	Fourth wheel & pinion (Cal.5C23A)	4246 525	Buzzer lead terminal
241 859	Fourth wheel & pinion (Cal.5C20A)	4246 526	Alarm lead terminal
261 800	Minute wheel	4259 855	Anti-magnetic shield plate
271 801	Hour wheel (Cal.5C23A)	4270 525	Battery connection (—)
271 802	Hour wheel (Cal.5C20A)	4281 525	Alarm setting spring
281 800	Setting wheel	4283 530	Alarm wheel clamp (Cal.5C20A)
☆282 855	Clutch wheel (Cal.5C20A)	4457 530	Circuit block cover (Cal.5C23A)
☆282 858	Clutch wheel (Cal.5C23A,5C20A)	4457 534	Circuit block cover (Cal.5C20A)
☆354 800	Winding stem (For alarm)	011 570	Lower hole jewel for step rotor
☆354 856	Winding stem	011 537	Upper hole jewel for fourth wheel
383 800	Setting lever (For alarm)	011 568	Upper hole jewel for step rotor
383 855	Setting lever	011 570	Upper hole jewel for third wheel
384 800	Yoke (For alarm)	011 570	Upper hole jewel for fifth wheel
384 855	Yoke (Cal.5C20A)	022 427	Battery clamp screw
384 856	Yoke (Cal.5C23A)	022 436	Train wheel screw
388 800	Setting lever spring (For alarm)	022 436	Alarm set indicate lever screw
389 855	Setting lever axle spring	022 436	Circuit block cover screw
391 801	Train wheel setting lever	022 436	Setting wheel plate complete screw
☆470 720	Day star with dial disk (Cal.5C23A)	022 436	Setting lever spring screw (For alarm)
604 800	Minute wheel bridge	022 780	Date dial guard screw (Cal.5C23A)
610 800	Alarm set indicate lever (Cal.5C23A)	022 780	Alarm wheel Clamp screw (Cal.5C20A)
610 801	Alarm set indicate lever (Cal.5C20A)	☆022 197	Tube for train wheel bridge (A)
644 800	Alarm setting jumper	☆027 198	Tube for train wheel bridge (B)
701 855	Fifth wheel & pinion	☆027 199	Tube for circuit block cover screw (B)
712 801	Guide plate for date dial (Cal. 5C23A)	☆027 200	Tube for circuit block cover screw (A)
737 800	Date corrector setting wheel (Cal. 5C23A)	027 201	Tube for battery clamp screw
766 800	Intermediate minute wheel	☆027 202	Tube for setting wheel plate complete screw (A)
☆801 635	Date dial (Cal.5C23A)	☆027 203	Tube for setting wheel plate complete screw (B)
808 800	Date dial guard (Cal.5C23A)	027 204	Setting lever spring screw pin (For alarm)
810 800	Date jumper (Cal.5C23A)	☆027 205	Tube for date dial guard screw (A)
816 800	Date driving wheel (Cal.5C23A)	☆027 206	Tube for date dial guard screw (B)
837 800	Alarm set indicate lever guard	027 300	Alarm switch pin
☆866 526	Holding ring for dial (Cal.5C23A)	027 305	Guide pin for battery clamp
948 800	Alarm wheel (Cal.5C23A)	027 796	Setting lever pin
948 801	Alarm wheel (Cal.5C20A)	027 797	Yoke pin
950 800	Intermediate alarm wheel	027 798	Setting lever pin (For alarm)
962 855	Intermediate wheel for calendar correction (Cal.5C23A)	027 799	Alarm set indicate lever pin
963 725	Snap for day star with dial disk (Cal.5C23A)	☆Maxell SR721W	Silver oxide battery
986 855	Day-date corrector wheel rocking lever	☆SEIKO TR721W	Silver (II) oxide battery
4001 525	Circuit block	4589 801	Piezoelectric element

☆⇨ Please see remarks on the reverse page.

Part numbers in light letters are not shown in photos.

Cal. 5C20A, 5C23A

Remarks :

Clutch wheel (Cal. 5C20A)

- ☆282 855 } There are two types of clutch wheel in Cal. 5C20A.
 ☆282 858 } Refer to the illustration below.



☆282 855.....at 9 o'clock position.



☆282 858.....at 3 o'clock position.

Winding stem

- ☆354 800 (For alarm) } The type of winding stem is determined based on the design of cases and dials.
 ☆354 856 } Check the case number and refer to "SEIKO Quartz Casing Parts Catalogue" to choose a corresponding winding stem.



☆354 856.....at 9 o'clock position.

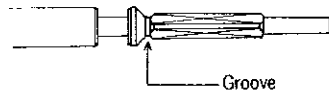

☆354 800 (For alarm).....at 3 o'clock position.

Day star with dial disk (Cal. 5C23A)

- ☆470 720 (English-Spanish, Black figures on white background).....
 Used when the crown, winding stem (For alarm) and calendar frame are located at 3 o'clock position, and winding stem 9 o'clock position.
 If any other type of day star with dial disk is required, specify the number printed on the disk.

Date dial (Cal. 5C23A)

- ☆801 635 (Black figures on white background).....
 Used when the crown, winding stem (For alarm) and calendar frame are located at 3 o'clock position, and winding stem is 9 o'clock position.
 If any other type of date dial is required, specify ① Cal. No. ② Jewels ③ The crown position ④ The calendar frame position and ⑤ Dial No.

Holding ring for dial (Cal. 5C23A)

- ☆866 526.....The type of holding ring for dial is determined based on the design of cases and dials.
 Check the case number and refer to "SEIKO Quartz Casing Parts Catalogue" to choose an appropriate holding ring for dial.

Tube for train wheel bridge A, B, Tube for circuit block cover screw A, B, Tube for setting wheel plate complete screw A, B, Tube for date dial guard screw A, B.

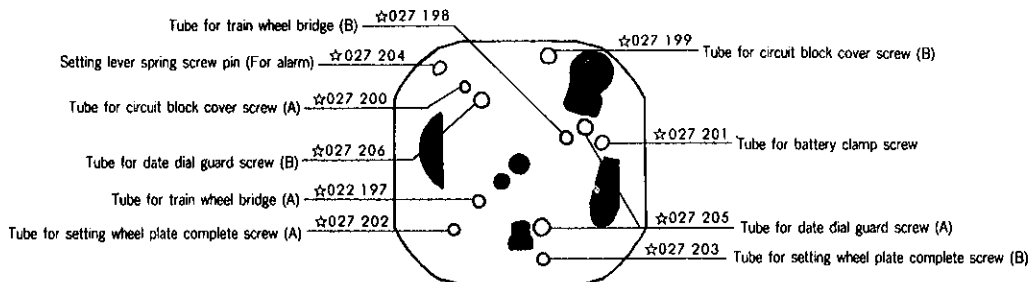

Battery

- ☆Maxell SR721W } The substitutive battery might be authorized in the future.
 ☆SEIKO (SEIZAIKEN) TR721W } In that case, please refer to separate "BATTERY LIST FOR SEIKO QUARTZ WATCHES".
 Note that SEIKO battery is marked with "SEIZAIKEN" on its (+) side.

TECHNICAL GUIDE

SEIKO
QUARTZ

CAL. 5C20A
CAL. 5C23A

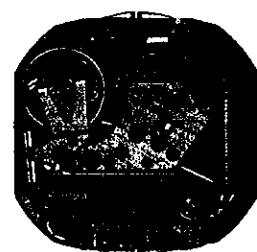
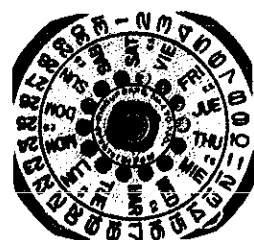

I. SPECIFICATIONS

Cal. No.	5C20A	5C23A	
Item			
Time indication	2 hands	3 hands	
Alarm time indication	Alarm index hand		
Additional mechanism	<ul style="list-style-type: none"> • Alarm function (Rings for 20 seconds) • Electronic circuit reset switch 		
	—	<ul style="list-style-type: none"> • Day & date calendar • Train wheel setting device • Battery life indicator 	
Loss/gain	Monthly rate at normal temperature range: less than 15 seconds		
Movement size	Outside diameter	24.6 mm 21.0 mm between 3 o'clock and 9 o'clock sides 22.0 mm between 6 o'clock and 12 o'clock sides	
	Casing diameter	24.0 mm 21.0 mm between 3 o'clock and 9 o'clock sides 22.0 mm between 6 o'clock and 12 o'clock sides	
	Height	2.9 mm	3.3 mm
Regulation system	Pattern cutting system		
Measuring gate by quartz tester	Use 10-second gate.		
Battery	SEIKO (SEIZAIKEN) TR721W, Maxell SR721W Battery life is approximately 2 years. Voltage: 1.55V		

II. STRUCTURE OF THE CIRCUIT BLOCK

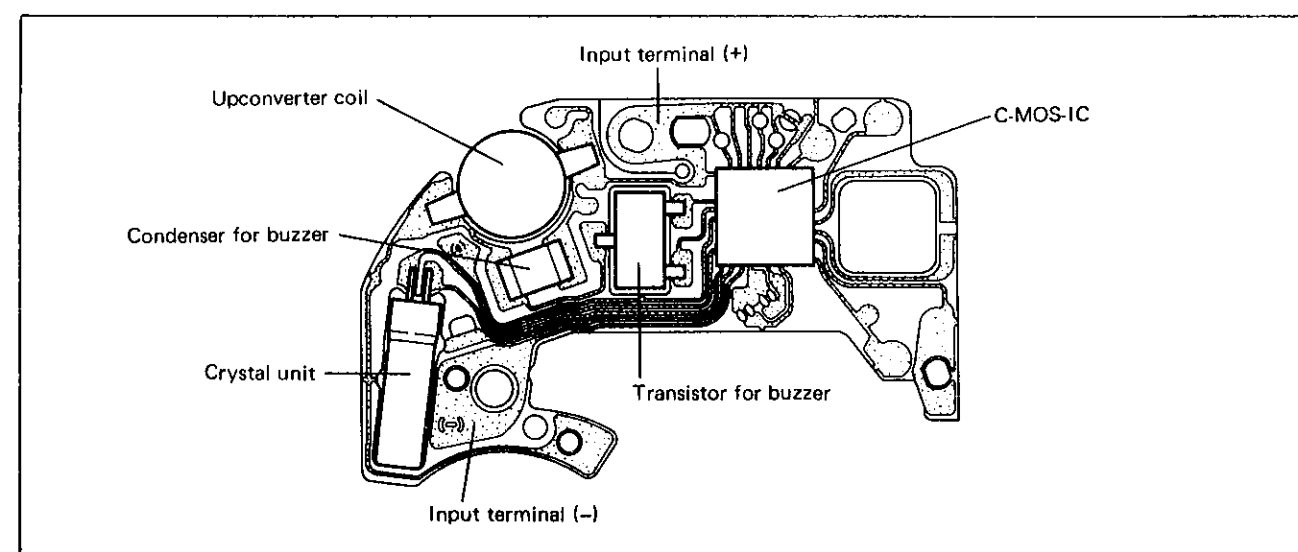

III. DESIGNATION AND OPERATION

Ex.: Cal. 5C23A

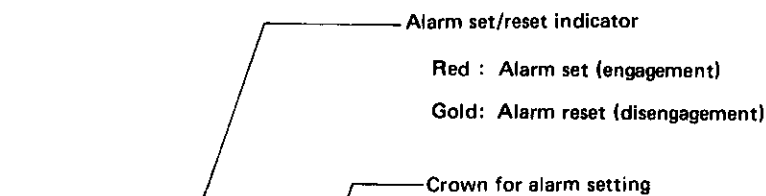
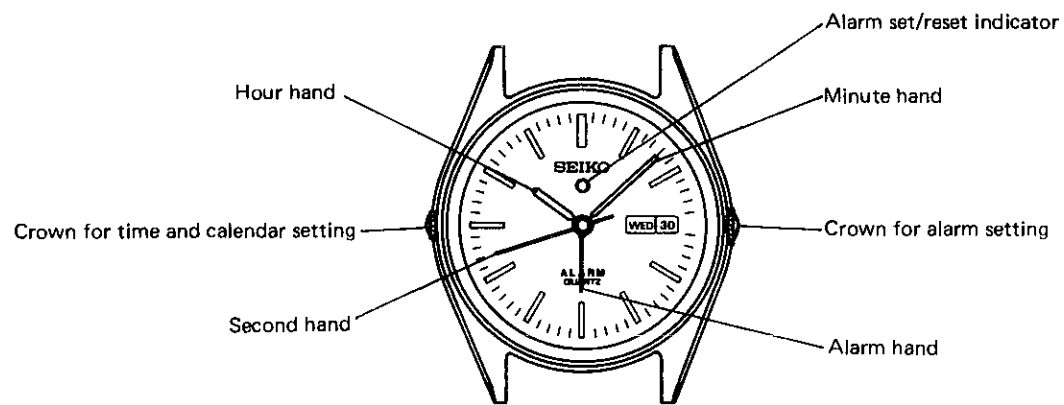

Red : Alarm set (engagement)
Gold: Alarm reset (disengagement)

Crown for alarm setting	Alarm set/reset indicator
Normal position: Alarm reset (disengagement)	Gold
1st click: Alarm engagement	Red
2nd click: Alarm time setting	Red

Crown for time and calendar setting

Normal position: Free

1st click: Calendar (day and date) setting

2nd click: Time setting

* The two crowns can be operated independently of each other.

IV. DISASSEMBLING, REASSEMBLING, AND LUBRICATING

1. How to install the hands

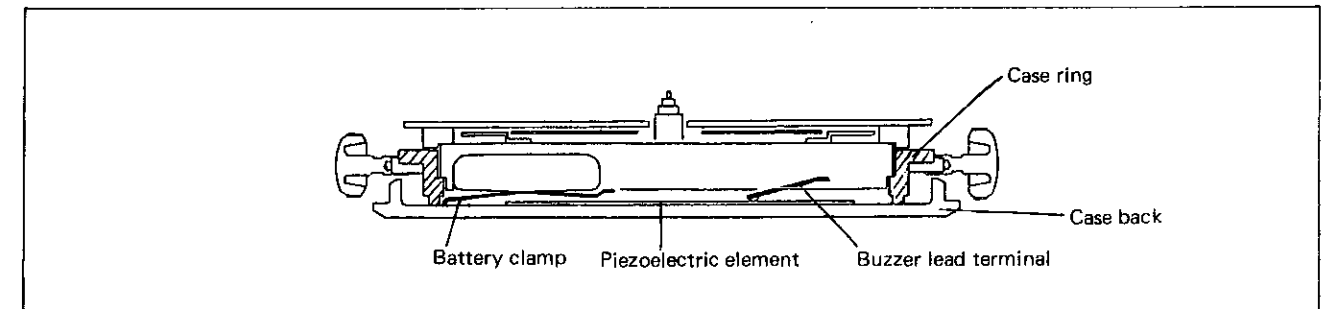

Since the alarm hand is installed, the hands setting procedure is different from that of ordinary analogue quartz watches. Install the hands, following the steps below.

- 1) Push in the 9 o'clock position crown completely and confirm that the step rotor is moving.
- 2) (Only for models with calendar)
Pull out the 9 o'clock position crown all the way and turn it counterclockwise until the date has just changed to the next.
- 3) Install the case ring into the inside of the case back, and then set the movement on it so that the buzzer lead terminal touches the piezoelectric element and the end of the battery clamp also touches the case back.



- 4) Pull out the 3 o'clock position crown all the way, then turn it slowly so that the alarm hand turns counterclockwise click by click, and stop turning it when the alarm starts ringing.
- 5) With the 9 o'clock position crown pulled out completely, turn it clockwise to turn back the minute hand approximately 30 minutes and then turn it counterclockwise to advance the hands slowly until the alarm starts ringing.
- 6) Keeping the crowns at these positions, install the alarm, hour, and minute hands on the 12 o'clock position of the dial.
- 7) Turn back the hour and minute hands a little, and then advance them slowly to locate their positions where the alarm starts ringing.
- 8) Install the second hand on the 12 o'clock position.

2. How to distinguish the stem and the case between their respective two types

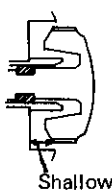
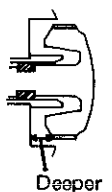
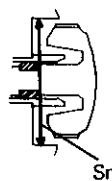
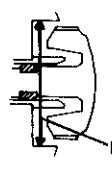
		9 o'clock side	3 o'clock side
Stem			
Case	Cal. 5C20A	 The case's groove for a crown is shallower than that of 3 o'clock side. Shallower	 The case's groove for a crown is deeper than that of 9 o'clock side. Deeper
	Cal. 5C23A (with calendar)	 The case's groove for a crown is smaller than that of 3 o'clock side. Smaller	 The case's groove for a crown is larger than that of 9 o'clock side. Larger

3. List of the screws used

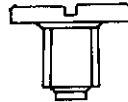
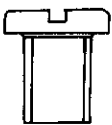
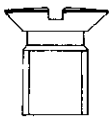
Shape	Part No.	Name	Shape	Part No.	Name
	022 436	Circuit block cover screw (2 pcs.)		022 427	Battery clamp screw (1 pc.)
		Setting lever spring screw (for alarm) (1 pc.)			
		Screw for alarm set indicate lever guard (1 pc.)		022 780	Date dial guard screw (Cal. 5C23A)
		Train wheel bridge screw (2 pcs.)			Alarm wheel clamp screw (Cal. 5C20A)
Setting wheel plate complete screw (2 pcs.)					

4. Disassembling, reassembling, and lubricating of the module

(1) Disassembling, reassembling, and lubricating of the setting mechanism

Disassembling procedures Figs.: ① → ③①
 Reassembling procedures Figs.: ③① → ①

Lubricating: ● Moebius A
 Normal quantity

● Second hand ~ Guide plate for date dial

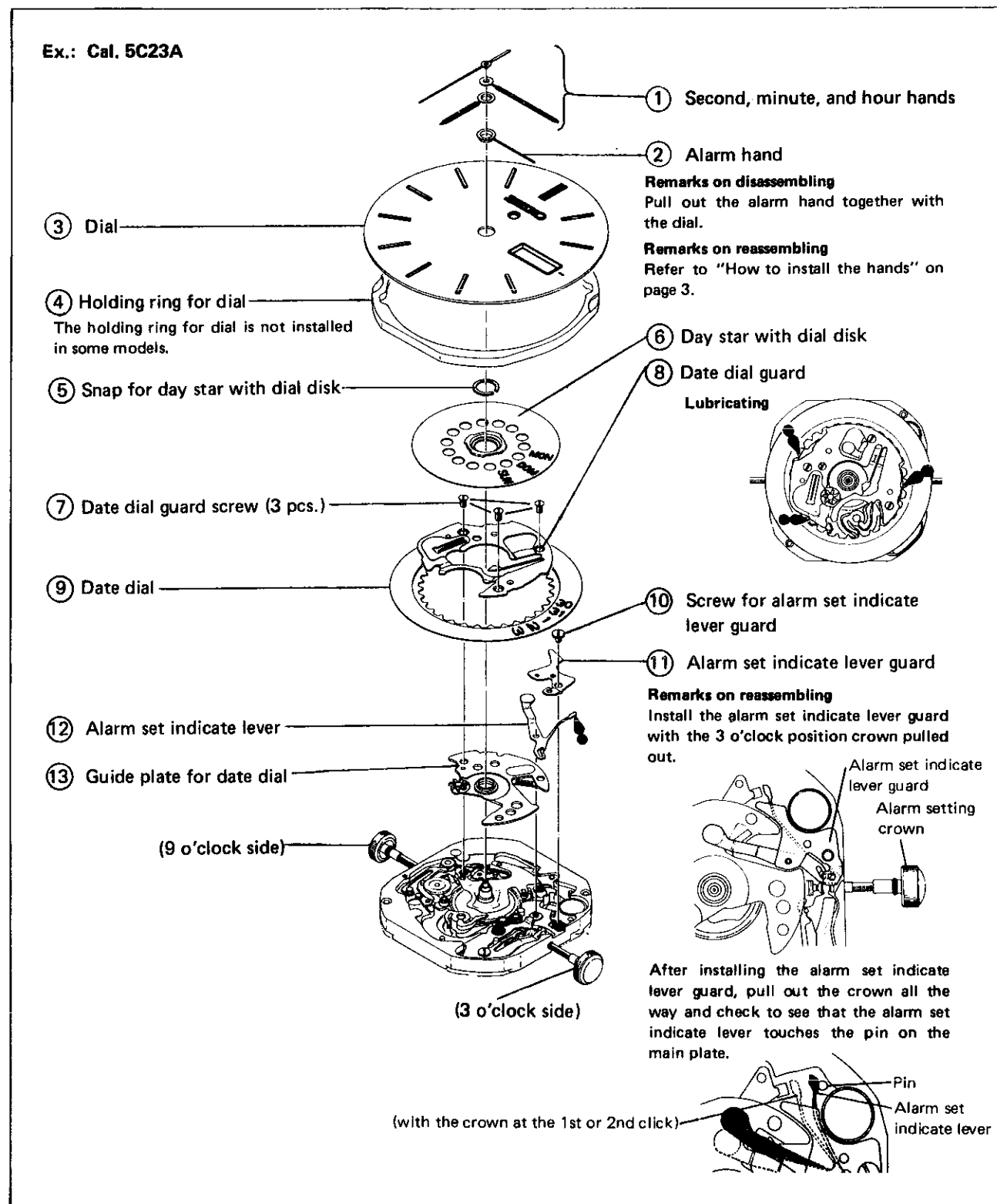

• Calendar corrector setting wheel ~ Date driving wheel

Lubricating: ● Moebius A
Normal quantity

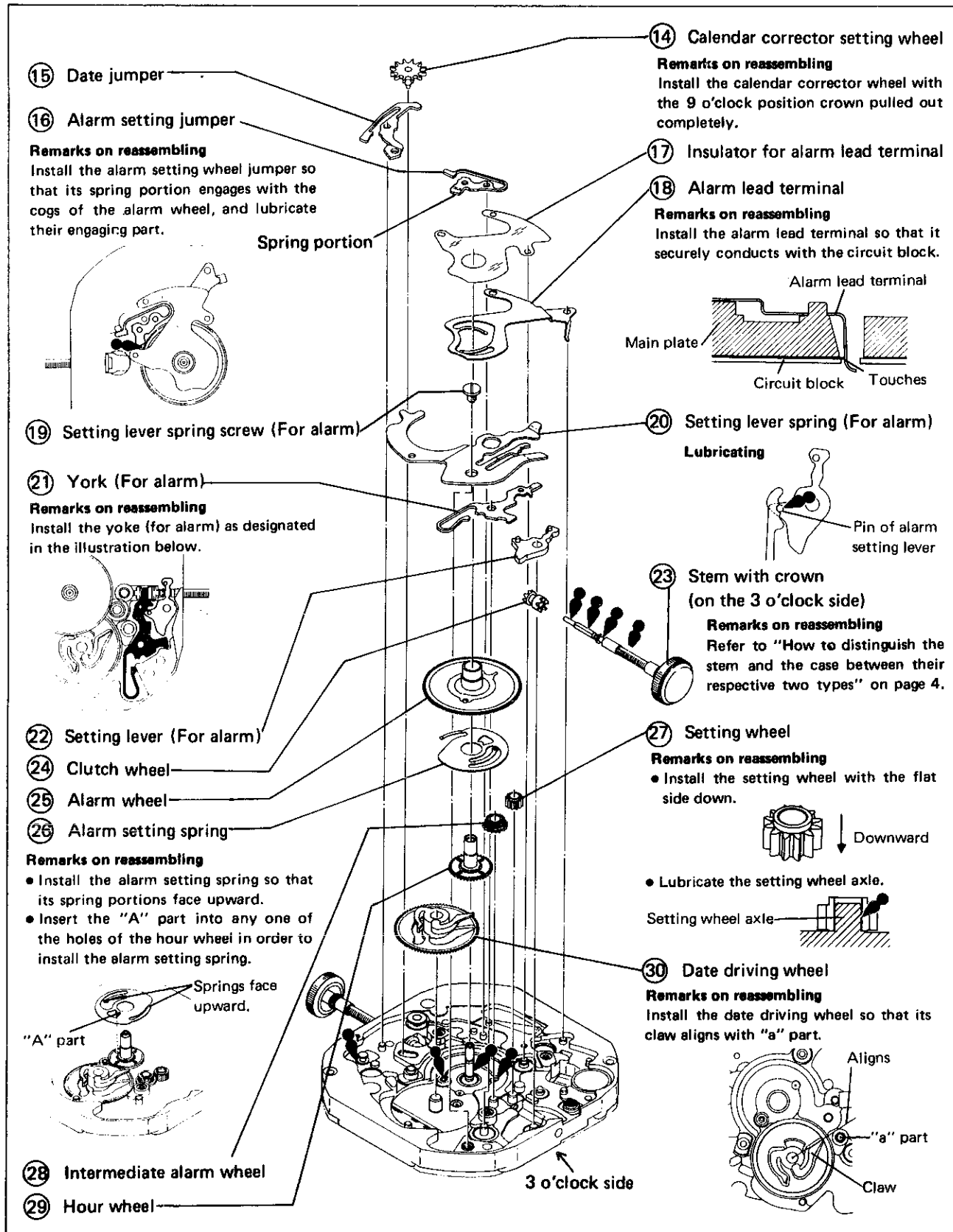

(2) Disassembling, reassembling, and lubricating of the gear train mechanism

Disassembling procedures Figs.: ① → ③③
Reassembling procedures Figs.: ③③ → ①

Lubricating: ● Moebius A
Normal quantity

• Battery clamp screw ~ Rotor stator

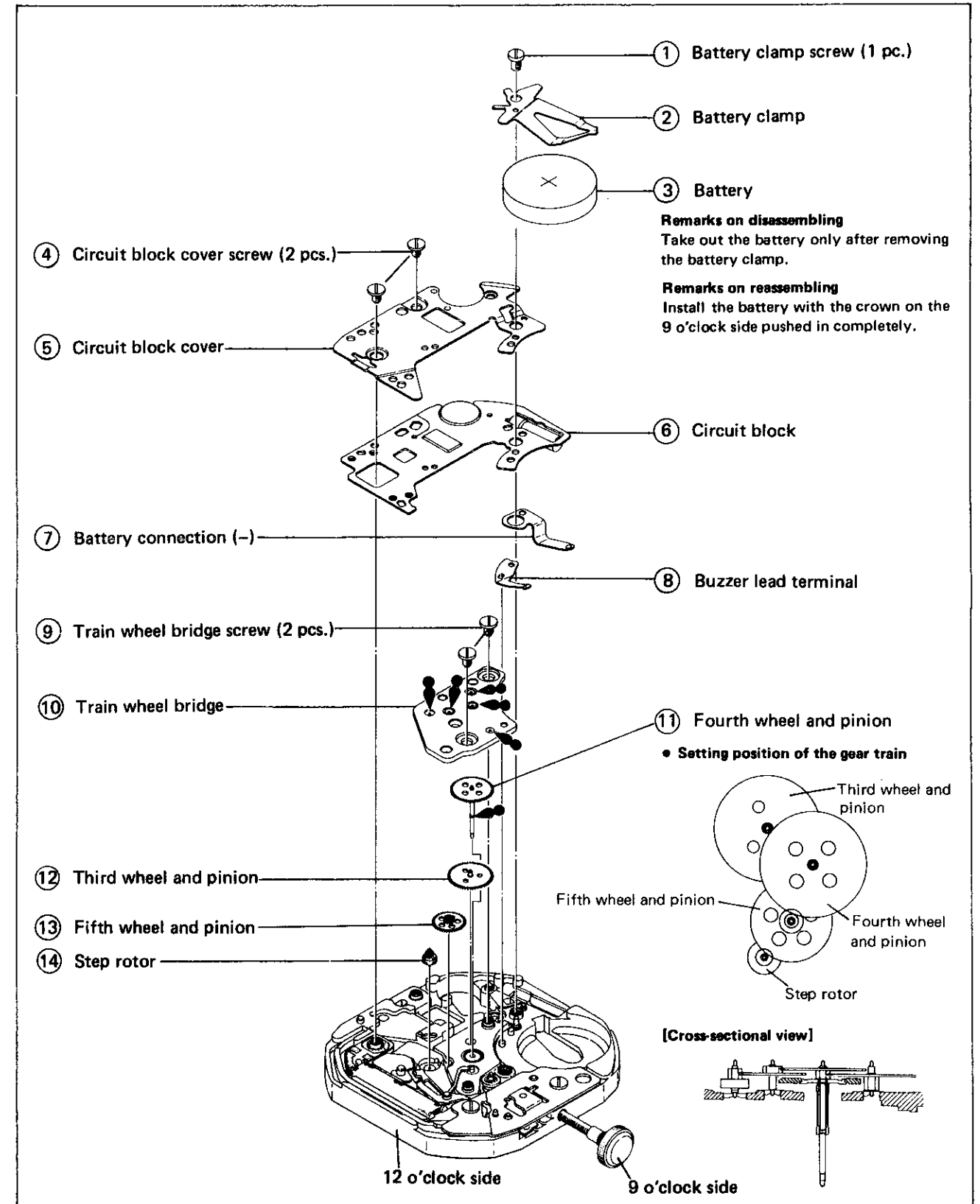

● Setting wheel plate complete screw ~ Main plate

Lubricating: ● Moebius A
 ○ SEIKO Watch Oil S-6
 Normal quantity

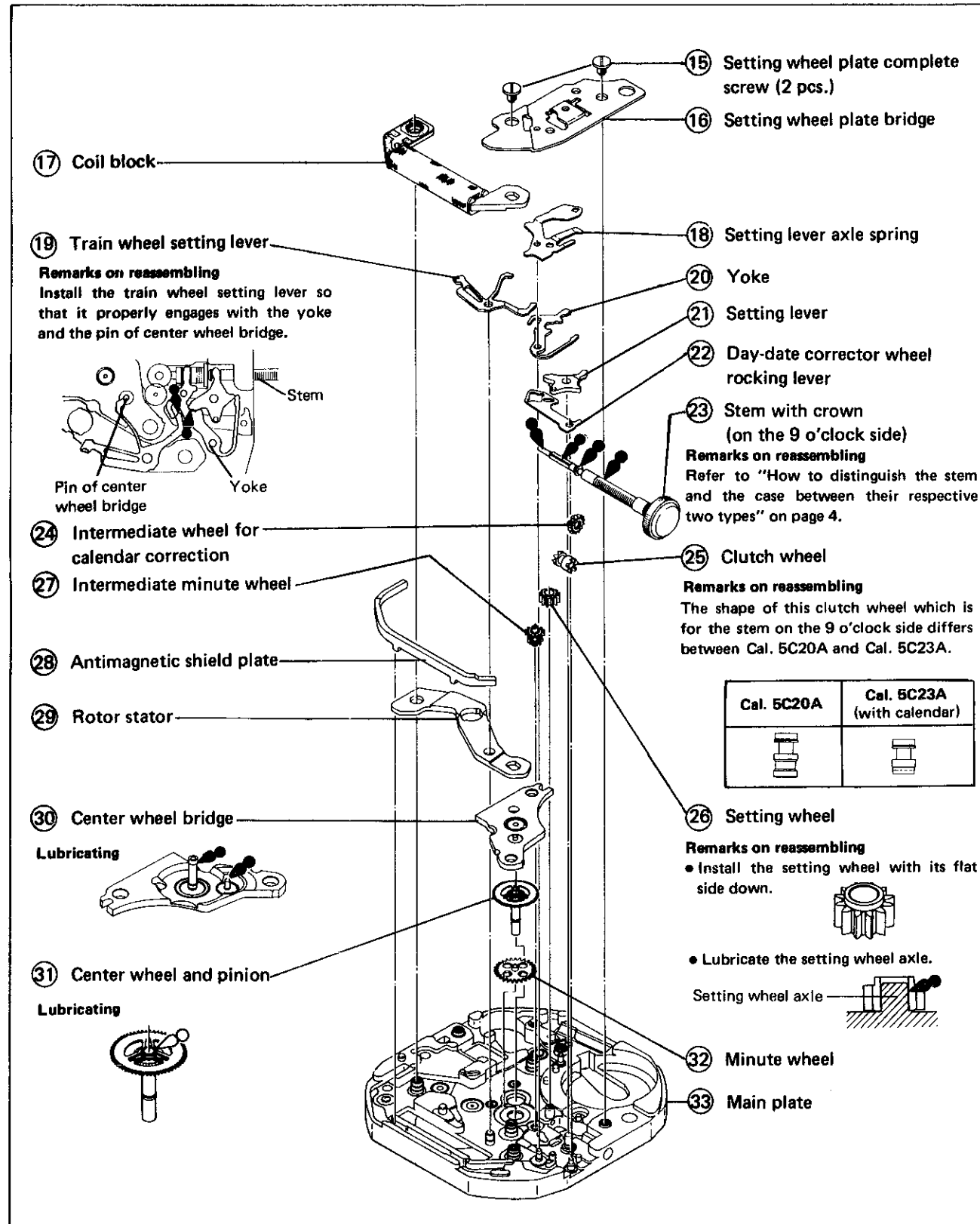

V. CHECKING AND ADJUSTMENT

● The explanation here is only for the particular points of Cals. 5C20A and 5C23A.
 Refer to the "TECHNICAL GUIDE, GENERAL INSTRUCTION" for SEIKO Analogue Quartz for details.

Procedure									
CHECK OUTPUT SIGNAL									
Use the quartz tester. Range to be used: 10-second gate									
CHECK HANDS SETTING CONDITION									
CHECK BATTERY VOLTAGE									
Use the Digital Multi-Tester. Mode to be used: DC V									
● When taking out the battery, remove the battery clamp in advance.									
CHECK COIL BLOCK									
Use the Digital Multi-Tester. Mode to be used: Ω									
<table border="0"> <tr> <td>Result:</td> <td></td> </tr> <tr> <td>Normal</td> <td>: More than 1.57V</td> </tr> <tr> <td>Defective</td> <td>: Less than 1.57V</td> </tr> </table>		Result:		Normal	: More than 1.57V	Defective	: Less than 1.57V		
Result:									
Normal	: More than 1.57V								
Defective	: Less than 1.57V								
CHECK ALARM SET CONDITION (by using the 3 o'clock position crown)									
<table border="1"> <thead> <tr> <th>Crown position</th> <th>Alarm</th> </tr> </thead> <tbody> <tr> <td>Normal position</td> <td>Alarm set indicator is gold.</td> </tr> <tr> <td>1st click</td> <td>Alarm set indicator turns red.</td> </tr> <tr> <td>2nd click</td> <td>Alarm hand turns both clockwise and counter-clockwise smoothly. Alarm rings when the alarm hand corresponds with the hour hand.</td> </tr> </tbody> </table>		Crown position	Alarm	Normal position	Alarm set indicator is gold.	1st click	Alarm set indicator turns red.	2nd click	Alarm hand turns both clockwise and counter-clockwise smoothly. Alarm rings when the alarm hand corresponds with the hour hand.
Crown position	Alarm								
Normal position	Alarm set indicator is gold.								
1st click	Alarm set indicator turns red.								
2nd click	Alarm hand turns both clockwise and counter-clockwise smoothly. Alarm rings when the alarm hand corresponds with the hour hand.								

Procedure

CHECK ACCURACY

Use the 10-second gate of the quartz tester.

How to adjust time accuracy
(Pattern cutting regulation system)

1. Confirm the appropriate pattern to be cut over the circuit block cover.
(-) pattern: to lose approximately 0.26 sec./day
(+) pattern: to gain approximately 0.26 sec./day
2. Take off the circuit block cover.
3. Cut the pattern.
4. Remove the sludge completely.

Ex.: The illustration below (Cal. 5C23A) shows that the (+) pattern is cut to gain time.

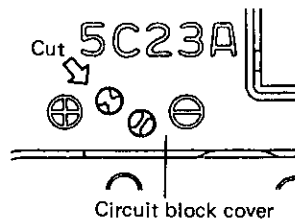

CHECK CURRENT CONSUMPTION

- Be sure to protect the movement from light with black paper while measuring.
- Do not check current consumption under an incandescent lamp, since strong light may cause a watch to consume excess current.

Use the Digital Multi-Tester.
Mode to be used: μA

1. Current consumption for the whole of the module

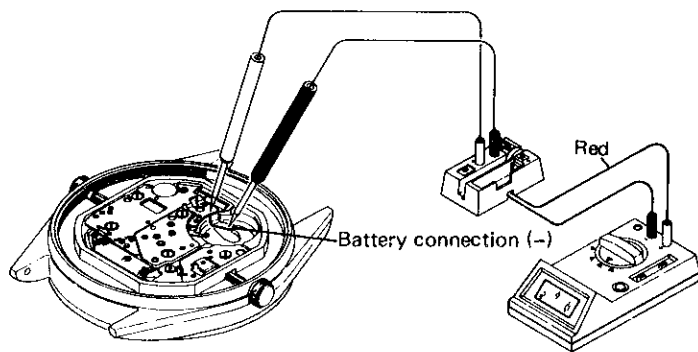

Result:
Normal : Less than $1.3\mu A$
Defective : More than $1.3\mu A$

2. Current consumption for the circuit block alone

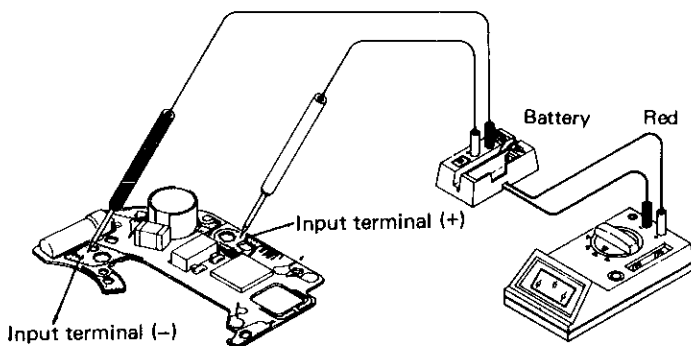

Result:
Normal : Less than $0.4\mu A$
Defective : More than $0.4\mu A$

Procedure

CHECK ALARM TEST SYSTEM

Pull out the 3 o'clock position crown completely and turn it counterclockwise.
Check to see that the alarm rings when the alarm hand coincides with the hour hand.



CHECK ALARM CONDITION

1. Check to see if there is any contamination on the piezoelectric element on the inside surface of the case back and the connecting portion of the buzzer lead terminal and if there is any deformation of the buzzer lead terminal.

Result:
Normal : Neither contamination nor deformation
Defective — Contaminated
Wipe of contamination.
Deformed
Rectify the shape with tweezers or replace the buzzer lead terminal with a new one.

2. Measure the resistance for the upconverter coil of the circuit block.

Use the Digital Multi-Tester.
Mode to be used: Ω

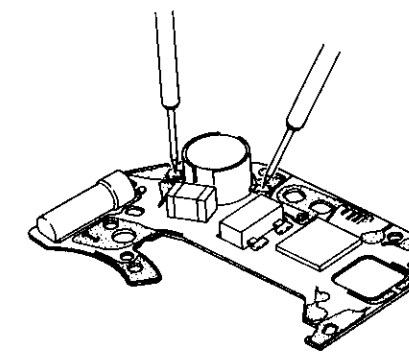

Result:
Normal : $40\Omega \sim 90\Omega$
Defective — Less than 40Ω
(Short circuit)
More than 90Ω
(Broken wire)